

Supply Chain Manual

Date of Publication: July 17th, 2017

Table of Contents

Table of Contents	2
Preface	4
1. Communication SUPPLIER - IBS FILTRAN.....	5
1.1. Contacts and Availability	5
2. Information Exchange.....	5
2.1. Electronic Data Interchange (EDI).....	5
2.2. Order Processing.....	5
2.2.1. Delivery Schedules	5
2.2.2. Individual Orders.....	5
2.2.3. KANBAN	5
2.2.4. ASN (under VDA4913)	6
2.3. Cumulative Quantities.....	6
2.4. Material and Production Releases.....	6
2.5. Ramp-up/Ramp-down Management	6
3. Logistics Controlling	7
3.1. Safety Stock.....	7
3.2. Delivery Frequency.....	7
3.3. Deviations from Standard Procedures.....	7
3.4. Overshipment / Advance Delivery	8
4. Packaging	8
4.1. Determination of Packaging	8
4.1.1. Stackability & Suitability for Storage.....	9
4.1.2. Corrosion Protection	9
4.2. Specifications of Weight and Dimensions	9
4.3. Labeling (VDA Label 4902)	10
4.4. Label Format.....	11
4.5. New Part Label	11
4.6. Durable Packaging property of IBS FILTRAN	12
4.6.1. Inventory, inventory count and Rotating Stocks of Load Units.....	12
4.6.2. Shortage of Load Units	12
4.6.3. Empty Container Management and Return	12
4.6.4. Maintenance of Load Units.....	12

5.	Dispatch Logistics.....	13
5.1.	Incoterms.....	13
5.2.	Freight Forwarders.....	13
5.3.	Transfer of Risk.....	13
5.4.	Premium Freights.....	13
6.	Customs.....	14
6.1.	Export Documents.....	14
6.2.	Declaration of Security.....	14
6.3.	Long-term Supplier's Declaration.....	14
6.4.	Special Requirements for Wooden Packaging in International Trade.....	14
7.	Miscellaneous.....	15
7.1.	Shutdown Periods.....	15
7.2.	Time Windows.....	15
7.3.	Supplier Ratings.....	15
8.	List of Abbreviations.....	16
9.	List of Illustrations.....	17
10.	Distribution, Archiving, Revisions and Releases.....	18
10.1.	Distribution and Archiving.....	18
10.2.	Revisions and Releases.....	18

Preface

Since its foundation in 1986, IBS FILTRAN supplies filter systems for automatic transmissions to all major automotive and transmission manufacturers worldwide.

In this regard, the importance of logistics is rising throughout the company, and as a competitive factor it is a major key to economic success.

Due to this fact, IBS FILTRAN is facing constantly increasing logistics requirements in international competition.

The present Supply Chain Manual helps to standardize the supply relationships between the respective SUPPLIER and IBS FILTRAN, in order to ensure a smooth collaboration as well as to establish a common understanding of the logistics process.



Illus. 1: IBS FILTRAN GmbH company site

1. Communication SUPPLIER - IBS FILTRAN

1.1. Contacts and Availability

A competent contact person must be named by the SUPPLIER, as well as an appropriate substitute. E-mail addresses, phone and fax numbers must be listed for the contact person, the substitute and their supervisor.

The SUPPLIER ensures that the contact person is fluent in German language, as well as English language in case of company locations abroad.

Availability of the contact (or substitute) named by the SUPPLIER must be given between 8 am to 4 pm on working days.

For availability outside the above mentioned time frame (or in shutdown periods), the SUPPLIER provides the mobile phone number of a qualified emergency contact.

2. Information Exchange

2.1. Electronic Data Interchange (EDI)

In general, all data exchange between the SUPPLIER and IBS FILTRAN is transferred electronically, in order to guarantee efficient and reliable processes. For this purpose, two electronic types of connection are provided:

- Standard EDI
- Web EDI via the portal Logistic Solution Professional (LSP) by Seeburger AG

The SUPPLIER is responsible for choosing a type of information and implementing the EDI connection, whereas the Web EDI option is recommended only for SUPPLIERS with low order volumes.

2.2. Order Processing

2.2.1. Delivery Schedules

Delivery Schedules are submitted on a rolling basis. Updated regularly, they map a horizon of at least 6 months in general. The latest delivery schedule is binding and replaces all former schedules.

2.2.2. Individual Orders

Prototype parts and low volume materials are mostly requested by individual orders by e-mail, fax or post. For individual orders, an order acknowledgement is mandatory.

2.2.3. KANBAN

This scheduling procedure is mostly applicable for A-parts with constant consumption. This scheduling procedure is favored by IBS FILTRAN.

Within a KANBAN procedure, all necessary information regarding material and production releases are additionally submitted as forecast delivery schedule. However, the KANBAN call-off solely is valid for delivery.

2.2.4. ASN (under VDA4913)

With the electronic data exchange option agreed upon, the SUPPLIER provides a dispatch advice (ASN) via standard EDI or Web EDI within 15 minutes after dispatch. The ASN has to be conform with the delivery documents. It is important to prevent that the ASN can be sent before dispatch.

2.3. Cumulative Quantities

The SUPPLIER ensures that the cumulated delivered quantity always matches the cumulated received quantity of IBS FILTRAN. In case of nonconformity, the reason for the deviation has to be resolved immediately with the responsible SCM-Analyst at IBS FILTRAN.

On **January 1st of each year**, IBS FILTRAN will reset the cumulated delivered quantity to zero (Rollback). The SUPPLIER has to follow the same procedure.

2.4. Material and Production Releases

Based on the delivery schedule the SUPPLIER ensures,

- to have sufficient production capacity for this volume and
- that its pre-suppliers are capable of supplying the raw materials accordingly.

In general, material and production release periods are specified in the supply contract (standard: 30 days of production release and 60 days of material release). Should the release periods as agreed prove to be insufficient to maintain delivery capability, the SUPPLIER may request an extension of the material release or additional forecast figures in individual cases. All of these requests have to be directed to the Purchasing Department at IBS FILTRAN.

In case an order is cancelled within the production release period and there are no follow-up orders, IBS FILTRAN will decide about call-off of the products within a time frame to be agreed upon, or payment of the purchase price.

In case an order is cancelled within the material release period and there are no follow-up orders, IBS FILTRAN will refund the material costs to the SUPPLIER – subject to the condition that the SUPPLIER can prove that this material cannot be used otherwise in an appropriate time frame. IBS FILTRAN reserves the right to reclaim the raw materials already paid for.

2.5. Ramp-up/Ramp-down Management

During Ramp-up/Ramp-down phases, IBS FILTRAN expects any SUPPLIER to increase their flexibility. Detailed planning is necessary to be able to supply even smaller quantities in due time.

Ramp-up/Ramp-down timing has to be coordinated between IBS FILTRAN and the SUPPLIER in due course.

Especially during Ramp-down phase, it is important to ensure that material releases are adhered to with regard to quantity and timing.

3. Logistics Controlling

3.1. Safety Stock

In general, IBS FILTRAN pursues the strategy of high inventory turnover and thus avoids in-house safety stock.

The safety stock quantity is stipulated in working days and shall be provided by the SUPPLIER at the SUPPLIER'S own expenses and own risk. IBS FILTRAN may carry out a random check for availability of the safety stock stipulated. In case of stock falling below the agreed safety stock, the SUPPLIER is obliged to immediately notify the responsible SCM - Analyst at IBS FILTRAN and take special actions to replenish the safety stock.

In general, depending on the respective order volume, the safety stock is specified with 3 working days unless separate agreements have been made.

3.2. Delivery Frequency

The delivery frequency as shown in the delivery schedules describes the frequency of deliveries from the SUPPLIER to IBS FILTRAN. This frequency is individually agreed upon with each SUPPLIER. It must be noted that the due date shown in the delivery schedules is the arrival date at IBS FILTRAN.

3.3. Deviations from Standard Procedures

In case of any interference that affects due dates or quantities towards IBS FILTRAN, all necessary actions have to be initiated by the SUPPLIER. In case any agreements or commitments cannot be met despite the actions taken, the SUPPLIER shall alert the responsible SCM-Analyst at IBS FILTRAN immediately and unsolicitedly, to coordinate a new delivery date or quantity.

Furthermore, the SUPPLIER shall unsolicitedly inform IBS FILTRAN about the following:

1. Root cause of the bottleneck
2. Availability of production capacity for the parts overdue as well as applicable machine occupation times and shifts (working days / hours per week) based on a recovery plan
3. Alternative production lines (must be audited and released by IBS FILTRAN)
4. Possible partial shipments
5. Possibility of shortening transit times by special transports
6. Information/escalation within the SUPPLIER's organisation

If no mutual agreement can be found, the SUPPLIER shall involve higher hierarchy levels through to the Managing Director (CEO).

In case of violation of obligations under this Supply Chain Manual, IBS FILTRAN reserves the right to claim damages from the SUPPLIER by means of a logistics claim form. In addition to the expenses incurred, IBS FILTRAN will always charge a blanket administrative fee of 150 Euro.

In the case of quality deviations, the processing of complaints will be handled by IBS FILTRAN's Quality Management.

3.4. Overshipment / Advance Delivery

Generally, overshipments and advance deliveries are not permitted.

Advance authorization by the responsible SCM-Analyst of IBS FILTRAN is mandatory for any overshipment or advanced delivery. Non-authorized overshipments or advanced deliveries will either be returned at the SUPPLIER'S expense, or the SUPPLIER will be charged for external storage. Alternatively, IBS FILTRAN reserves the right to adjust the value date of the invoice.

4. Packaging

4.1. Determination of Packaging

In general, all packaging between IBS FILTRAN and the SUPPLIER must adhere to common ecological, economical and qualitative standards already during quotation phase. Within the product development process, the SUPPLIER is obliged to carry out the development of packaging as well. In conclusion, the responsible packaging manager at IBS FILTRAN and the SUPPLIER will determine the packaging per part number as specified by a packing instruction form (F320-017_packaging instruction for suppliers, download available at www.ibs-filtran.com). This packing instruction is binding for all future deliveries of the contract products. Non-compliance with the packing instruction as determined will automatically trigger a complaint. Any additional costs arising from this complaint (e. g. for sorting or re-packing actions) will be charged to the SUPPLIER.

As a rule, a packing instruction approved and signed by the responsible packaging manager at IBS FILTRAN is mandatory for all deliveries (as of PPAP release).

The SUPPLIER respects the following principles:

- Packaging must not be bigger or more elaborate than absolutely necessary for protection of the goods.
- Any filling materials should be avoided.
- The VDA-Label 4902 is an integral part of the packaging release. The corresponding requirements are listed in chapter 4.3.
- For both disposable and durable packaging, recyclable materials shall be used and marked in accordance with any specifications given by the waste management industry.
- Only pure materials shall be used (no composite materials).
- Metal closures, brackets and strips are not permitted.
- Disposable packaging shall be avoided wherever possible. Any deviations must be coordinated beforehand with the responsible packaging manager at IBS FILTRAN.
- It is preferable to utilize durable packaging suitable for pooling (Euro pallet, Euro wire mesh box, VDA small load carrier, etc.).
- Regarding utilization of durable packaging owned by IBS FILTRAN, see chapter 4.6.
- Durable packaging shall also preferably be defined for any inserts (such as blister inserts, see chapter 4.6.4. Maintenance of Load Units)
- Durable containers shall be designed to guarantee complete emptying, as well as easy cleaning and drying.
- Polyester bags must be used for coating the insides of all containers.

- All parts must be packed and delivered according to type. This applies in particular to deliveries of the same part number under different states of revision (index change).

4.1.1. Stackability & Suitability for Storage

Suitability for storage and ergonomical parts handling shall be guaranteed by appropriate packaging. In special cases, individual packaging may be required upon prior agreement.

Both individual as well as multi item box units (such as sets, bulk materials, etc.) shall be closed suitable for transportation and storage.

All loading units must sustain dynamic triple stacking without any deformation or other damages. Any deviations must be coordinated beforehand with the responsible Packaging Manager at IBS FILTRAN.

4.1.2. Corrosion Protection

For any parts subject to corrosion, corrosion protection must be considered for the entire logistics process. The type of corrosion protection must be determined beforehand with the responsible Packaging Manager at IBS FILTRAN.

4.2. Specifications of Weight and Dimensions

- Maximum dimensions of packaging unit (incl. pallet) are 1200 x 800 x 1050 [mm] (LxWxH).
- Maximum total weight of packaging unit incl. tare must not exceed 450 kg.
- Maximum total weight of single loading units (e. g. SLC or cardboard box) must not exceed 12 kg.
- In the selection of packaging weights and dimensions, any rules by the employer's Liability Insurance Association as well as any recommendations by the Institute of Organizational Management (automotive-specific) shall be adhered to.

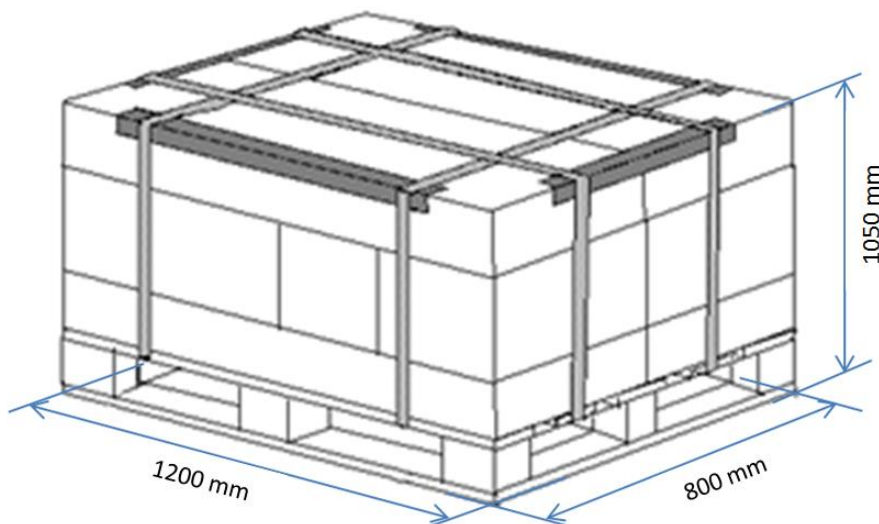

Illus. 2: Standard pallet dimensions

4.3. Labeling (VDA Label 4902)

In order to maintain a continuous logistics information concept at IBS FILTRAN, as well as a more efficient processing of all material flow data in compliance with the requirements for traceability, all product and transport packaging must be marked with barcode labels according to VDA 4902, unless otherwise agreed with the responsible Packaging Manager at IBS FILTRAN.

The **SUPPLIER** respects the following principles:

- The key syntax must be contained in the barcode, but shall not be visible in plain text.
- Sections 8, 15 and 16 of the label are limited to 18 characters.
- Barcode labels must be attached to the packaging in a position well visible from the outside.
- A barcode label must be attached to each packaging unit.
- The barcode label must indicate the batch number.

The label must be attached in a clearly visible position. From the label, part description and part number must be clearly recognizable. **The label must be attached to the front side on the upper left corner.** All information on the VDA label as well as the barcode itself must be readable and must not be covered by safety straps.

(1) Warenempfänger IBS Filtran GmbH 51597 Morsbach		(2) Abladestelle		
(3) Lieferschein-Nr (N) 87214198 		(4) Lieferantenschrift		
(8) Sach-Nr Kunde(P) 1-1090-101 		(5) Gewicht netto (KG) 80	(6) Gewicht brutto (KG) 165	(7) Anzahl Packst. 3
(9) Füllmenge (G) 80 		(10) Bezeichnung Lieferung Grundkörper 8HP65A		
(12) LieferantenNR (V) 		(11) Sach-Nr Lieferant(30S) 295.295.218.295		
(15) Packstück-Nr (S) 34335590 		(13) Produktionsdatum P 27.06.2013		(14) Änderungsstand Konstrukt.
		(16) Chargen-NR (H)		

VonPlatz

Illus. 3: Barcode label under VDA 4902

4.4. Label Format

The label of the packaging unit must be in DIN A5 horizontal format.

Depending on the packaging unit type, labels with a format of 210 x 74 mm (VDA Norm) might also be required (e. g. SLC 4314).

- a) Barcode section (3) "Lieferschein-Nr." (**delivery note no.**) must contain the key syntax **N**
- b) Barcode section (8) "Sach-Nr. Kunde" (**customer ref.**) must contain the key syntax **P**
- c) Barcode section (9) "Füllmenge" (**quantity**) must contain the key syntax **Q**
- d) Barcode section (15) "Packstück-Nr." (**container no.**) must contain the key syntax **S**
- e) Barcode section (16) "Chargen-Nr." (**lot no.**) must contain the key syntax **H**

The key syntax must be contained in every section of the barcode (plausibility check during scanning process), but shall not be visible in plain text.

Field lengths of the label sections are limited to a total of 18 characters each (incl. syntax).

4.5. New Part Label

The first 5 deliveries of a new part number or an already existing part number after a technical modification must additionally be marked with a label referring to „New Part / Index Change“. This label helps IBS FILTRAN to reliably realize any technical modifications and also to document further use in all following assemblies.

Design: A5 format, black letters on an orange background, printed on strong paper or cardboard:

<u>NEUES TEIL / NEW PART</u>	
Artikel-Nr. / Part-No.	50-05-0285
Lieferant / Supplier	XYZ
Bezeichnung / Description	Bottom Pan
Herstellungsdatum / Manufacturing date	18.04.2017
Lieferdatum / Delivery date	20.04.2017
Änderungsindex / Revision	B

Illus. 4: Form: F320-012_Labeling of New or Modified Parts

This form can be downloaded from <http://www.ibs-filtran.com/unternehmen/downloads/>

4.6. Durable Packaging property of IBS FILTRAN

4.6.1. Inventory, inventory count and Rotating Stocks of Load Units

Once per year, IBS FILTRAN performs a physical inventory count of self-owned load units. Information on the date and volume will be communicated by the Logistics Planning Department. If required, an additional inventory count of load units can be performed. The SUPPLIER is obliged to provide support during the inventory count on a cost-neutral basis.

4.6.2. Shortage of Load Units

In order to ensure security of supplies, the SUPPLIER shall immediately report any missing load units to the responsible SCM Analyst or Packaging Manager at IBS FILTRAN.

4.6.3. Empty Container Management and Return

Return of empty containers to the SUPPLIER depends on production lots, delivery frequencies and the rotating stock amount determined by IBS FILTRAN and the SUPPLIER.

Unless otherwise agreed, any freight charges for empty container return to the SUPPLIER will be stipulated according to the Incoterm as per contract, as follows:

- In the case of FCA (Free Carrier): freight costs are carried by IBS FILTRAN
- In the case of DAP / DDP (Delivered at Place / Delivered Duty Paid): freight costs at SUPPLIER's expense

4.6.4. Maintenance of Load Units

IBS FILTRAN provides the load units for the SUPPLIER in a clean and undamaged condition.

Cleanliness of the load units must be maintained and verified by the SUPPLIER before dispatching the material in the load units to IBS FILTRAN. Damaged load units shall be blocked by the respective user without exception for any further usage. The Packaging Manager at IBS FILTRAN must be informed immediately about the circumstances of the damage or contamination. Relevant photo documentation shall be provided in a timely manner.

After receipt of the load units, the SUPPLIER is responsible for proper storage of the load units, as well as protection against bad weather. Contamination of the load units must be prevented at any time before, during and after production process.

Non-compliance of these specifications will result in cleaning measures or replacement at the SUPPLIER's expense.

To avoid confusion of parts in the further process, only the most recent VDA label from the current delivery shall be attached to the load unit.

Note: Any misuse or external use of pool packaging owned by IBS FILTRAN is not permitted.

5. Dispatch Logistics

IBS FILTRAN corporate strategy is to have all SUPPLIERS submit quotes under Incoterm DAP (Incoterms® 2010), with costs for freight and packaging stated separately. This strategy helps to analyze the overall cost.

5.1. Incoterms

The following Incoterms® 2010 find application in supplies to IBS FILTRAN:

- FCA „Place of Departure“
- DAP „Place of Receipt“
- DDP „Place of Receipt“

5.2. Freight Forwarders

Under the Incoterm FCA, the SUPPLIER shall only use freight forwarders and parcel services specified by IBS FILTRAN. Exceptions can only be made in justified cases and with the prior written consent of the SCM Analyst at IBS FILTRAN.

Note: If the contractually agreed Incoterm is FCA, the SUPPLIER is responsible for proper cargo declaration towards the forwarding agency nominated by IBS FILTRAN. Should there be any commercial penalties arising from wasted journey or dead freight, IBS FILTRAN reserves the right to charge back all additional costs to the SUPPLIER.

5.3. Transfer of Risk

Transfer of risk happens at the time when IBS FILTRAN or its subcontractor physically takes over the goods at the delivery point according to the agreed Incoterm. The SUPPLIER is responsible for any damages or losses before this point in time. Any damages or missing / wrong labels detected later in the process will be inspected by IBS FILTRAN for their cause. If applicable, a quality complaint will be sent to the SUPPLIER.

Any faulty parts shall be replaced immediately by the SUPPLIER. In order to ensure supplies to IBS FILTRAN, the SUPPLIER is obliged to define, notify and implement measures for process reliability.

The SUPPLIER will be charged with all consequential costs triggered by missing parts, wrong parts or by damages caused by the SUPPLIER or its subcontractors.

5.4. Premium Freights

Special transports will usually be organized by the SUPPLIER. The SUPPLIER shall coordinate with IBS FILTRAN which forwarder is to be used.

Special transport costs shall be covered by the party who caused the damage. If any costs are forwarded to IBS FILTRAN, the prior written consent of the SCM Analyst at IBS FILTRAN is mandatory.

Under no circumstances shall the SUPPLIER organize a special transport at IBS FILTRAN's expense, unless there is a written confirmation from IBS FILTRAN which clearly indicates the acceptance of costs.

For special transports, the valid packing instruction must also be adhered to.

6. Customs

6.1. Export Documents

The SUPPLIER shall provide all necessary documents for customs clearance. This also includes documents for preferential origin as well as national Certificates of Origin, where applicable.

REGION	STANDARD DOCUMENTS
Europe	EUR 1, Certificate of Origin FORM A and Commercial Invoice
- Turkey	A.TR, Commercial Invoice
North America	Bill of Lading and Commercial Invoice
Asia	Customs documents to be coordinated with IBS FILTRAN
- China	Commercial Invoice, Packing List, IPPC Certificate
- Japan	Commercial Invoice, Packing List

6.2. Declaration of Security

The SUPPLIER shall declare a „Known Consignor“ status (under (EG) Nr. 300/2008) towards all service providers (Regulated Agents) used, by submitting a „Declaration of Security“ (see www.lba.de for the latest forms and explanations) and undertakes to adhere to all conditions resulting from this.

For air freight, only cooperation with Regulated Agents is permitted.

6.3. Long-term Supplier's Declaration

IBS FILTRAN is obliged to make reliable statements towards its customers regarding the trade origin as well as the preferential status of the goods.

It is mandatory for all SUPPLIERS to state the commercial and preferential origin of all components supplied to IBS FILTRAN.

Thus, the preferential status of goods must be attested by appropriate preference documents (Long-term Supplier's Declaration) on a regular basis, at least once a year.

6.4. Special Requirements for Wooden Packaging in International Trade

In international trade, the phytosanitary regulations of IPPC (International Plant Protection Convention), a subsidiary organization of FAO (Food and Agriculture Organization of the UN), have to be adhered to regarding solid wood packaging. Any deviations from these regulations are subject to explicit approval.

Further information on the IPPC regulations as well as national regulations can be downloaded from:

<https://www.ippc.int/IPP/En/default.jsp>

7. Miscellaneous

7.1. Shutdown Periods

If material is called off during a shutdown period or on a bank holiday, the SUPPLIER is obliged to contact the responsible SCM Analyst at IBS FILTRAN immediately. The decision about postponement of delivery shall only be made by IBS FILTRAN. The SUPPLIER is not, under any circumstances, permitted to make this decision on its own, and has to accept the decision made.

In general, the SUPPLIER shall inform the responsible SCM Analyst at IBS FILTRAN about any shutdown dates planned.

7.2. Time Windows

It is IBS FILTRAN's objective to ensure a smooth inbound process within the receiving department. For this reason, individual delivery time windows shall be set up for each SUPPLIER.

Should an existing time window not be met by the SUPPLIER, this may automatically lead to longer unloading times.

For any deliveries outside the opening hours, IBS FILTRAN reserves the right to charge the costs occurred (e. g. by a considerable amount of extra work) to the SUPPLIER by means of a logistics claim.

7.3. Supplier Ratings

At least once a year, IBS FILTRAN performs a supplier rating, considering the above-mentioned items of the Supply Chain Manual. The SUPPLIER will be informed about the results. If necessary, actions shall be taken in order to achieve the A delivery performance requested by IBS FILTRAN.

8. List of Abbreviations

ASN	Advanced Shipping Notification
DAP	Delivered At Place
DDU	Delivery Duty Unpaid
EDI	Electronic Data Interchange
FAO	Food and Agriculture Organization
FCA	Free Carrier
Incoterm	International Commercial Term
IPPC	International Plant Protection Convention
KANBAN	Materials requirement planning technique developed by Toyota Corporation
LBA	Luftfahrt Bundesamt (German Federal Aviation Administration)
LTSD	Long-Term Supplier's Declaration
LSP	Logistic Solution Professional (Web-Portal by Seeburger AG)
PPAP	Parts Permission Approval Process
Rollback	Rollback of cumulative quantities to "0" at the beginning of each year
SCM	Supply Chain Management
UN	United Nations
VDA	Verband der Automobilindustrie (German Association of the Automotive Industry)

9. List of Illustrations

Illus. 1: IBS FILTRAN GmbH company site

Illus. 2: Standard pallet dimensions

Illus. 3: Barcode label under VDA 4902

Illus. 4: Form: F320-012_Labeling of New or Modified Parts

10. Distribution, Archiving, Revisions and Releases

10.1. Distribution and Archiving

Distribution and Archiving of this Supply Chain Manual is effected in accordance with V410 Data Management, and is stipulated in our matrix of documents (in German language: Dokumentenmatrix).

10.2. Revisions and Releases

Release of this Supply Chain Manual is subject to V410 Data Management, and is stipulated in our matrix of documents (in German language: Dokumentenmatrix). Verification of release is filed and archived by GSM (Global Standards Manager).

Index	Date	Section	Description and Reason of Revision	Created / Revised by	Reviewed and Released by *
01	01.07.2017	-	Initial Version	Dept. SCM	Thomas Habel

* per signature (Recommended: Release by Process Owner)

Future revisions of this Supply Chain Manual will be documented individually under 10.2. „Revisions and Releases“, and will trigger an allocation of a new index number for the entire document.